

Wiring

The wires are connected as follows:

- Black - Negative (ground) battery connection.
- Red - Switched power from the battery.
- Green - Ignition signal (configured for 4-pulse per rev).
- White - 12 Volt Dash Lighting.

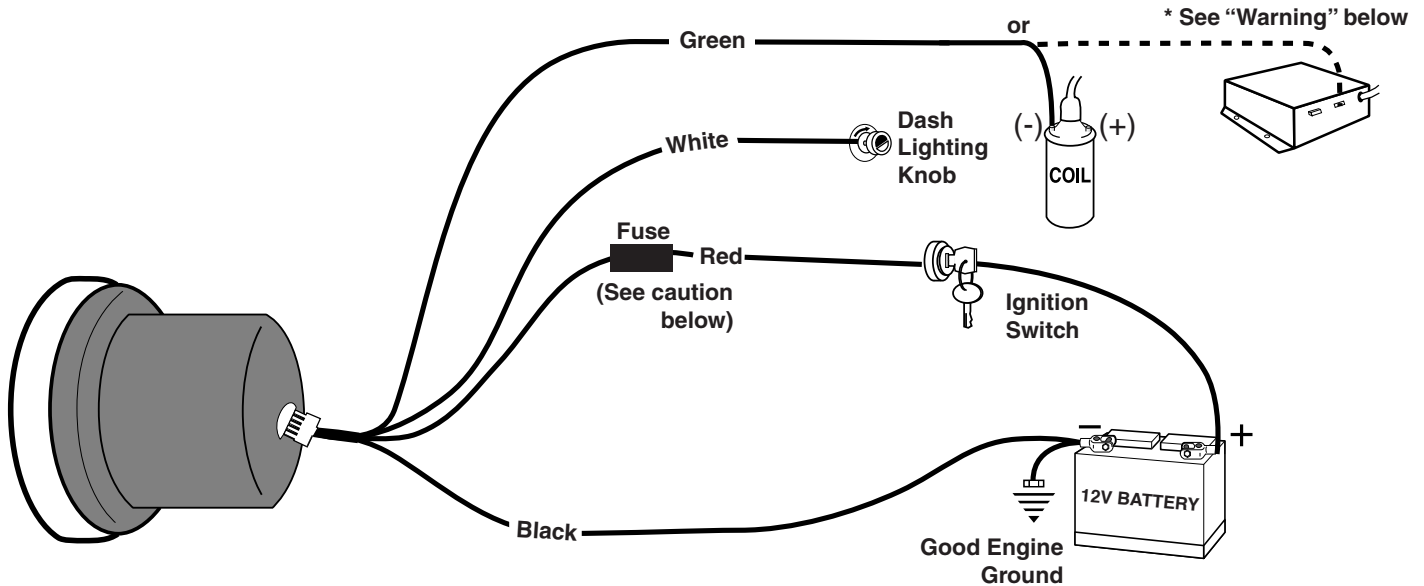

CAUTION!!!

As a safety precaution the RED wire of this product should be fused before connecting it to the positive (+) side of switched power source. We recommend using a 4 Amp, 3AG fast-acting type cartridge fuse (Littlefuse® #312 004 or an equivalent) inline with the RED wire of our product for tachs that use a Shift-Lite. For tachs without a Shift-Lite we recommend using a 1Amp 3 AG fast-acting type cartridge fuse (Littlefuse® #312 001 or an equivalent).

WARNING

Warranty will be void if connected to coil when using an aftermarket ignition box such as, but not limited to products from the following manufacturers: MSD, Crane, Jacobs, Mallory, Holley, Etc.. Prior to installation of your tachometer, check with the ignition box manufacturer for recommended tachometer signal location.

* See autometer.com/tech_installation.aspx for specific vehicle information.

Mounting

Pedestal

- 1) Loosen both bolts holding the shock strap to the mounting foot. Back both bolts out until each is only one or two turns into the spacer.
- 2) Pass tach wires through shock strap assembly and slide tach casing into shock strap assembly.
- 3) Adjust tach and mounting base to desired position and tighten bolts holding mounting foot to shock strap to secure the assembly.
- 4) The special design of the tachometer base allows for a variety of mounting possibilities. Attach the base using screws provided or use a pop rivet tool.

In-Dash

1. Mount tachometer in a $3\frac{3}{8}$ " dia. hole. Be careful not to cut the hole too large.
2. Cut $\frac{3}{8}$ " dia. hole in the firewall for the tachometer wires. Place a rubber grommet in the hole and route the wires through the grommet to the engine compartment.
3. Connect the tachometer wires as shown in the wiring sections.
4. Secure the tachometer to the dashboard using the provided bracket and hardware.

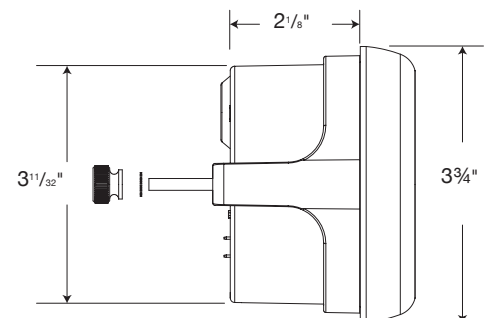

Normal Operation

The Elite Street tach uses the dial backlight as a shift light indicator. The RPM of the engine will indicate one of the following ranges:

NOTE: This table uses example values in the RPM RANGE and BACKLIGHT COLOR columns. These values are user selectable.

RPM RANGE	BACKLIGHT COLOR	BACKLIGHT MODE	COMMENTS
0-6,000	Green	Normal	Programming Mode 1
6,000-7,000	Yellow	Warning	Programming Mode 2
7,000-8,000	Red	Shift	Programming Mode 3
8,000	Flashing Red	Over-Rev	Programming Mode 4

These RPM ranges, the colors for each mode, the Pulses-Per-Rev (PPR), and Dimming Enable/Disable can be modified using the three buttons in the dial of the tach. These user selectable values are accessible from one of four programming modes.

Programming Mode 1 - Pulse Per Rev (PPR), Normal Backlight Color and Dimming Enable/Disable.

The Dimming mode is selected upon the entry to this mode. When this mode is entered, the voltage on the white wire is measured. If the voltage is above 1 volt, dimming is enabled, and the back light brightness will be proportional, following the voltage on the white wire. If the white wire is not connected, or the voltage is below 1volt, dimming is disabled, and the back light will be at full brightness 100% of the time.

To display and edit the current PPR and Normal Backlight color:

- Press all three buttons simultaneously. The pointer will move to the RPM that indicates the current PPR and back light will begin flashing once per second. Release all three buttons.
- Use the '+' (right) button and the '-' (left) button to move the pointer to the RPM that represents the desired PPR (see chart below).
- Press and release the ENTER (middle) button to capture and store the PPR. The back light will begin flashing twice per second.
- Use the '+' (right) button and the '-' (left) button to cycle through the seven back light colors.
- With the desired normal back light color active, press and release the ENTER (middle) button to capture and save the changes. If the there are no button presses for four seconds, the tach will return to normal tach mode without saving any changes.

NOTE: The pointer is used to indicate the PPR (Pulse Per Rev) setting in the tach per the following table:

ENGINE		Most 2 cyl.		Most 4 cyl.		Most 6 cyl.	Most 8 cyl.		
PPR	0.5	1	1.5	2	2.5	3	* 4	5	6
DIAL RPM	500	1000	1500	2000	2500	3000	4000	5000	6000

* Default Factory Setting

Programming Mode 2 Warning RPM and Backlight Color:

- To display Warning RPM, press and release the '+' (right) button:
- The pointer will display current Warning RPM, with the Backlight displaying the Warning color, for 4 seconds.
- To Edit Warning RPM, while the pointer and Backlight are displaying the Warning set point and color:

NOTE: Warning Point RPM cannot be set above the Shift Point RPM.

- Use the '+' (right) button to increase the pointer position and the '-' (left) button to decrease the pointer position until the pointer indicates the desired RPM. If the there are no button presses for four seconds, the tach will return to normal tach mode **without** saving the RPM change.
- Press and release the ENTER (middle) button to capture and save the new Warning RPM. The Backlight will begin flashing twice per second. If the there are no button presses for four seconds, the tach will return to normal tach mode, **saving** the Warning RPM point.
- While the backlight is flashing, use the '+' (right) button and or the '-' (left) button to advance through the seven color choices for the Warning Backlight. If the there are no button presses for four seconds, the tach will return to normal tach mode **without** saving any color changes.
- With the desired Warning back light color active, press and release the ENTER (middle) button to **save** the Warning Backlight color and RPM.

Programming Mode 3 - Shift Point RPM and Backlight Color:

- To display Shift Point RPM, press and release the ENTER (middle) button. The pointer will display current Shift Point RPM, with the backlight displaying the Shift Point color, for 4 seconds.
- To Edit Shift Point RPM, while the pointer and Backlight are displaying the Shift Point set point and color:

NOTE: Shift Point RPM can not be set below Warning Point RPM, or above Over-Rev Point RPM.

- Use the '+' (right) button to increase the pointer position and the '-' (left) button to decrease the pointer position until the pointer indicates the desired RPM. If there are no button presses for four seconds, the tach will return to normal tach mode **without** saving the RPM change.
- Press and release the ENTER (middle) button to capture and save the new Shift Point RPM. The Backlight will begin flashing twice per second. If there are no button presses for four seconds, the tach will return to normal tach mode, **saving** the Shift Point RPM point.
- While the back light is flashing, use the '+' (right) button and or the '-' (left) button to advance through the seven color choices for the Shift Point Backlight. If there are no button presses for four seconds, the tach will return to normal tach mode **without** saving any changes to the Backlight color.
- With the desired Shift Point back light color active, press and release the ENTER (middle) button to **save** the Shift Point Backlight color and RPM.

Programming Mode 4 - Peak Recall, Over-Rev Point and Backlight Color:

- To display the Peak RPM, press and release the '-' (left) button. The pointer will move to the Peak RPM captured for 4 seconds. The Backlight will change to the state of the captured RPM (i.e. if Over-Rev Point RPM is set to 8,000 rpm, and the captured peak is 8,300 rpm, the Backlight will begin flashing the Over-Rev color).

NOTE: Peak RPM values will only be recorded after the RPM has been above 3000 RPM for 3 seconds.

- To clear the recall Peak RPM, press and release the ENTER (middle) button while the Peak RPM is being shown. The tach will return to normal mode.
- To view the Over-Rev Point RPM, press the '+' (right) button while the Peak RPM is being shown. The pointer will move to Over-Rev Point RPM, with the backlight displaying the Over-Rev color, for 4 seconds. After 4 seconds of no button presses, the tach will return to normal mode.
- To Edit Over-Rev Point RPM, while the pointer and Backlight are displaying the Over-Rev set point and color:

NOTE: Over-Rev Point RPM cannot be set below Shift Point RPM.

- Use the '+' (right) button to increase the pointer position and the '-' (left) button to decrease the pointer position until the pointer indicates the desired RPM. If there are no button presses for four seconds, the tach will return to normal tach mode **without** saving the RPM change.
- Press and release the ENTER (middle) button to capture and save the new Over-Rev RPM. The Backlight will begin flashing twice per second. If there are no button presses for four seconds, the tach will return to normal tach mode, **saving** the Over-Rev RPM point.
- While the Backlight is flashing, use the '+' (right) button and or the '-' (left) button to advance through the seven color choices for the Over-Rev back light. If there are no button presses for four seconds, the tach will return to normal tach mode **without** saving any changes to the Backlight color.
- With the desired Over-Rev Backlight color active, press and release the ENTER (middle) button to **save** the Over-Rev Backlight color.

SERVICE

For service send your product to Auto Meter in a well packed shipping carton. Please include a note explaining what the problem is along with your phone number. If you are sending product back for warranty adjustment, you must include a copy (or original) of your sales receipt from the place of purchase.

12 MONTH LIMITED WARRANTY

Auto Meter Products, Inc. warrants to the consumer that this product will be free from defects in material and workmanship for a period of twelve (12) months from date of the original purchase. Products that fall within this 12 month warranty period will be repaired or replaced at Auto Meter's option to the consumer, when it is determined by Auto Meter Products, Inc. that the product failed due to defects in material or workmanship. This warranty is limited to the repair or replacement of parts in the Auto Meter instruments. In no event shall this warranty exceed the original purchase price of the Auto Meter instruments nor shall Auto Meter Products, Inc. be responsible for special, incidental or consequential damages or costs incurred due to the failure of this product. Warranty claims to Auto Meter must be transportation prepaid and accompanied with dated proof of purchase. This warranty applies only to the original purchaser of product and is non-transferable. All implied warranties shall be limited in duration to the said 12 month warranty period. Breaking the instrument seal, improper use or installation, accident, water damage, abuse, unauthorized repairs or alterations voids this warranty. Auto Meter Products, Inc. disclaims any liability for consequential damages due to breach of any written or implied warranty on all products manufactured by Auto Meter.

FOR SERVICE SEND TO: **AUTO METER PRODUCTS, INC.** 413 W. Elm St., Sycamore, IL 60178 (866) 248-6357

Email: service@autometer.com